



真富儲水式電熱水器

速熱

JENFORT® Storage Electric Water Heater

Speedy Heat

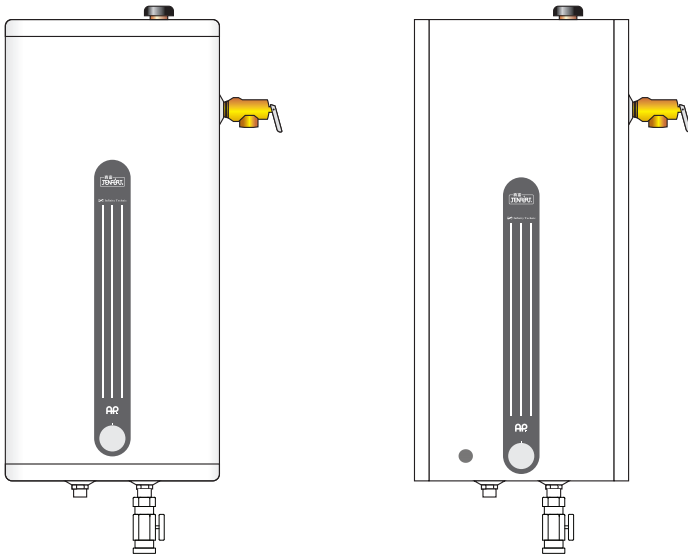

JH Series

安裝及操作使用說明書
Installation and Operation Manual

致各位客戶，
Dear Customers,

多謝選購真富JH(S)中央儲水速熱式電熱水器系列。
Thank you for choosing Jenfort JH(S) Series Multi-Point Shower Unit Storage Speedy Heat Type Electric Water Heater.

請閣下於安裝及使用電熱水器前，細閱本安裝及操作使用說明書，並保留此說明書作日後參考。

All customers MUST read this Installation and Operation Manual before installing and using your electric water heater. It is advised to keep this manual for future reference.

本電熱水器必須經由合資格的工程人員安裝及測試，才可使用。
All installation or inspection MUST be carried out by a qualified technician.

本電熱水器必須正確連接地線，才可使用。
This electric water heater MUST be properly earthed before use.

請確保兒童遠離本機。
Keep the appliance away from children.

請照顧好小孩，不要讓小孩把玩本機。
Children should be supervised to ensure that they do not play with the appliance.

兒童、長者及殘疾人士必須由成人或監護人的陪同下才可使用本電熱水器，以免發生燙傷或其他意外。
Children, elderlies and people with disabilities are only allowed to use this electric water heater if they are under the supervisions of an adult or a person responsible for their safety to prevent from scalding or other injuries.

如果閣下對本說明書有任何問題，請聯絡代理商或合資格的專業人士提取意見
If you have questions regarding this manual, please consult the agent or an authorized party for their professional advice.

榮獲 ISO9001: 2015 生產管理認證
Awarded ISO9001:2015 The Management System



榮獲香港工業總會優質標認局頒發
Awarded Hong Kong Q-Mark Product Scheme



維修服務熱線 : 3563 6960
Service Hot-line

總代理 Sole Agent

 A-PLUS (HK) GROUP LTD.
愛家(香港)集團有限公司

目錄

Table of Contents

1. 產品及配件 Product and Accessories	3
2. 產品特點 Product Features	4
3. 產品安裝指引 Product Installation Instructions	5-7
4. 安裝注意事項 Precautions for Installation	8
5. 產品操作指引 Product Operating Instructions	9
6. 操作注意事項 Precaution for Operations	9-10
7. 技術參數 Specification	11
8. 常見問題 Trouble Shooting	12
9. 保養條款 Warranty Terms and Conditions	13

★ 如本說明書有任何更改，恕不作另行通知★
This information in this manual is subject to change without prior notice★

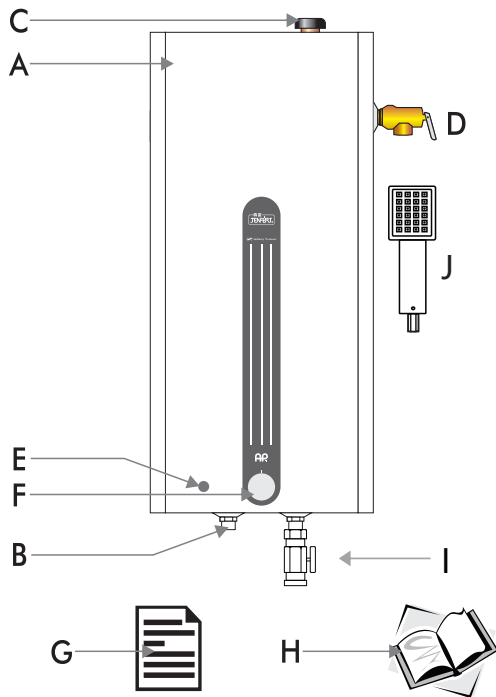

產品及配件 Product and Accessories

- A: 主機
Main Body
- B: 喉管接駁位置
Pipe Connector
- C: 防真空閥
Anti-vacuum Valve
- D: 溫度及壓力排放閥
Pressure & Temperature Relief Valve
- E: 指示燈
Light Indicator
- F: 恆溫制旋鈕
Thermostat Control Switch
- G: 保養咭
Warranty Card
- H: 安裝及操作使用說明書
Installation and Operation Manual
- I: 節流閥
- J: 專用慳水節能花灑頭
Energy Saving Shower Head

請注意：配件C、D、I及K是分開包裝、I為速熱爐專用配件。

Please note: Parts C、D、I and K packed separately, I flow limiter is particularly for Speedy Storage water heater.

- | | |
|---------------------------------------|--|
| E: 指示燈
Light Indicator | - 紅色：正在加熱
- Red light indicates water is in heating process |
| F: 恆溫制旋鈕
Thermostat Control Switch | - 向右轉可增加水溫
- 向左轉可減低水溫
- Turn clockwise to increase water temperature
- Turn anticlockwise to decrease water temperature |
| I: 節流閥旋鈕
Flow limiter knob | - 向右旋轉入水流量逐漸變小
- 向左旋轉入水流量逐漸變大
- Turn clockwise to reduce water entering in
- Turn anticlockwise to increase water entering in |

每一部電熱水器均包括以上之標準配件；如因使用未經許可的配件而導致任何損壞，客戶需自行負責因該損壞而造成的損失及責任。

Each unit is provided with standard accessories as stated above; if any damage occur is caused by using other unauthorized accessories, customer or user is responsible for their own loss and liability.

- 數碼溫度顯示屏*，精確溫度顯示，水溫一目了然
Digital temperature display, accurate temperature can be seen directly.
- 出水溫度穩定
Stable water temperature
- 在水壓不穩的情況下，仍可出水流暢
Suitable for unstable water pressure
- 防超溫安全保護裝置
Safety overheating protection
- 優質保溫層，保溫力特強並減少熱量流失，更能長時間保持熱水溫度，節能慳電
High density insulation layer reducing heat loss to minimal, temperature can be preserved longer hence saving energy.
- 符合國際電工協會 IEC-60335-1, IEC-60335-2-21 安全標準
Compliant to the IEC-60335-1, IEC-60335-2-21 Standard
- 5分鐘快速加熱，即可達到舒適水溫，以供淋浴用途**
It takes just 5 minutes to reach a comfortable temperature for the mornings freshen up.
- 熱水器內之熱水完全加熱後，即可有更持久之熱水供應**
After the complete tank is heated up, there will be a longer lasting supply of hot water.

* 顯示屏所顯示的溫度為加熱完成後速熱筒內的溫度。
The Digital Temperature Display indicates the temperature inside the Speedy tank.

** 需配合原裝配件使用
Original accessories should be used.

真富 JH 中央儲水式電熱水器系列之熱水器在水壓不穩的情況下，仍能提供穩定而流暢的熱水。為達致安全目的，JH 系列內置防超溫安全保護裝置。
Jenfort JH Series Central Storage Type Electric Water Heater can provide constant hot water under unstable water pressure situation. For safety purpose, JH Series also install an overheating protection system;

當水溫超出一定的水溫限制時，防超溫安全保護裝置會自動切斷電源。另設有優質保溫層，減少熱量流失，節省能源。
when water temperature exceeds the limit, the system will cut off the power automatically. In addition, for energy saving, the high density insulation layer can reduce heat loss to the minium.

3.2 喉管及壓力排放閥安裝指引

Pipe and Safety Valve installation instructions

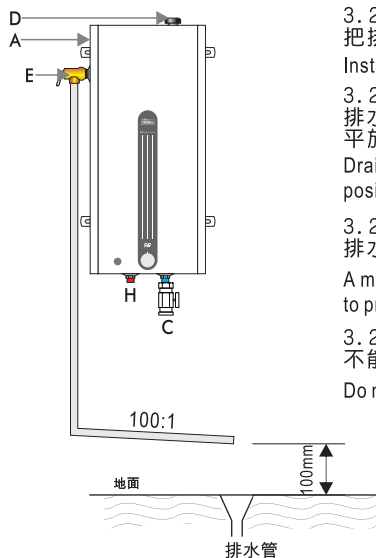

3.2.1

把排水管接駁至溫度及壓力排放閥。

Install the drain pipe to the pressure and temperature relief valve (PTV).

3.2.2

排水管的出口需垂直並指向最近的地面排水渠口；如水管需平放安裝，則需最少有100:1的斜度指向渠口。

Drain pipe outlet must point towards to the nearest drainage in vertical position; or lay on the floor with 100:1 gradient to the drainage.

3.2.3

排水管的出口需離開地面最小100毫米距離，以免做成堵塞。

A minimum clearance of 100mm between the floor and drain pipe outlet to prevent blockage.

3.2.4

不能把水管出口堵塞或接駁至其他配件。

Do not block or connect with other accessories to the drain pipe.

3.3 電源線接線圖示

Wiring Connection Diagram

3.3.1 接線圖

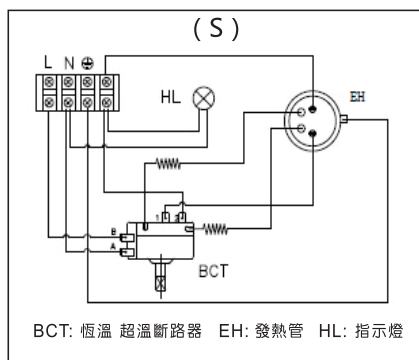
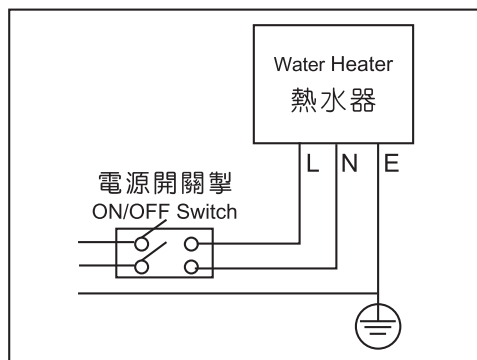

BCT: 恆溫 超溫斷路器 EH: 發熱管 HL: 指示燈

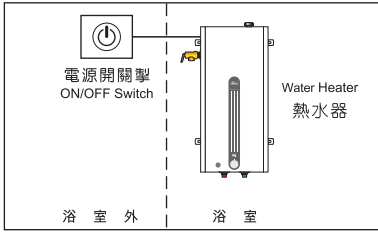

3.3.2

請安裝電源開關於浴室外之適當位置，然後用標準電線把電源開關及熱水器的電源接線座上相應的接線端連接好。

Install the power switch to an appropriate position outside the bathroom, connect the power switch with the corresponding wire terminal of the power terminal block of the water heater with standard wiring;

3.3.3

所有電線安裝必須根據發熱線的功率及當地的電力條例。載流量必須合乎熱水器的額定功率，並預留有額外安全容量。

Electrical supply installations must follow the power rating of heating element and the local electric power regulation. The current-carrying capacity must satisfy the water heater's rated power and have reserve for extra capacity.



警告

於完成安裝熱水器後，必須關閉電源，開啟水龍頭並轉至紅點位置，讓冷水及氣泡流出至少一分鐘，然後可關閉水龍頭。

此步驟只需在第一次安裝後、每一次維修後或暫停供水後進行，以避免因水箱沒水或合適的水量而導致發熱管損壞。

After the installation of the water heater, **power supply MUST be switched off the power supply** and turn the mixer tap to RED dot position, allow cold water and air bubble to flow out at least 1 minute, before turning off the mixer tap. This procedure is only require to do after the first installation, after every maintenance or during water shortage, it is to prevent the damage of the heating element when the inner tank is empty or without suitable water level.

- 4.1 安裝熱水器之基本條件
Basic conditions for electric water heater installation
- 4.1.1 必須使用經批准及安全的供電系統。
Must use approved and safe electricity supply system
- 4.1.2 必須使用經批准及穩定的供水系統。
Must use approved and stable water supply system
- 4.1.3 必須安裝於穩固的混凝土實心磚牆或足以承受熱水器的重量的牆壁上。
Must install in stable concretes solid brick wall or a wall strong enough to bear the weight of the heater
- 4.2 安裝熱水器之安全守則
Safety rules for electric water heater installation
- 4.2.1 此熱水器電源須獨立接駁於配电箱，並需跟據當地電力標準及條例。
Electrical wiring of the heater must directly connect to the Individual main supply following the standard and regulations of local electricity regulation;
- 4.2.2 根據使用電力條例及地方標準，熱水器必須連接至以下其中一種的安全斷路系統：
According to the usage of electricity regulations and local standard, it MUST be connected to one of the below open circuit system :
-合適的自動斷路系統
Suitable MCB System
-合適的漏電斷路系統
Suitable RCCB System
- 4.2.3 所有安裝必須由合資格的技術人員進行及完成，並使用原裝配件。代理商、生產商或供應商不會承擔因不正確或非授權之安裝引致的故障及損壞的責任。
Installation MUST be carried out and finished by a qualified licensed technician and using the original supplied accessories. The Sole Agent, manufacturer or suppliers is not responsible for any defect or damage caused by incorrect or unauthorized installation.
- 4.2.4 安裝的位置必須有足夠的地面排水位。
The position for the installation must provide adequate floor drainage
- 4.3 電源開關制必須達至國際電工協會 IEC 最新標準，並必須安裝於浴室之外。
The power supply switch must comply with latest IEC standard and it must be fixed outside the bathroom.
- 4.4 熱水器的安裝必須穩固，並正確地接駁電源。
The installation of the water heater must be stable and correctly connect with power supply.
- 4.5 為避免因重覆開關造成的觸電危險，本熱水器不能接駁任何外置的自動開關裝置。例如，定時器或者連接到由通用部件定時進行通斷的電路。
To avoid electrical shock caused by duplicated power supply, the appliance should not connect with any external automatic power supply devices e.g. timer or other power supply controlled by a specify device.
- 4.6 在沒有監督的情況之下，兒童、殘疾或傷殘人士都不應獨自操作本熱水器，以免燙傷、觸電或其他意外。
Do not allow children, physically or mentally disabled persons to operate this water heater without adult supervision to prevent the danger of scald, electrical shock or any other injuries.
- 4.7 若本產品之安全斷路器被啟動後，將不能自動重設。建議客戶由合資格技術人員進行重設斷路器及請必先關閉電源方可進行。
If the safety thermal cut out of the appliance has activated, it will not re-set automatically. Customer is recommended to re-set this device by a qualified technician and MUST disconnect the power supply before re-set.
- 4.8 安裝掛牆式熱水器時，建議安裝於離地面至少150厘米的位置。
When installing a wall-mounted unit, a minimum clearance of 150 cm is recommended from the floor to the unit.

5.1 操作指南 Operating Guide

- 5.1.1 熱水器必須安裝於一個正確的位置，並依照安裝指引進行後方可使用。
Must install the water heater in a proper location and follow the installation instructions before use.
- 5.1.2 開啟熱水器之前，請確保水箱內含水；當開啟電源後，紅色顯示燈亮起，熱水器會立即開始加熱。
Make sure the inner tank has water and switch on the power supply, the system will immediately start heating up and the heating indicator Red light will on.
- 5.1.3 當水溫達到預設的溫度時，加熱指示燈會熄滅。
When the water temperature reaches the pre-set temperature, the heating indicator will go out.
- 5.1.4 當使用熱水時，首先開啟水龍頭並轉至藍點位置流出冷水，再逐漸轉至紅點方向放出熱水並調較至適合沐浴之水溫。
When using hot water, turn the mixer tap to the BLUE dot position for cold water first, then gradually turn the mixer tap towards the RED dot position for hot water to adjust the water temperature to a suitable level for showering.

6. 操作注意事項

Precautions for Operations

- 6.1 由於水可能會從溫度及壓力排放閥的水管出口排出，因此該水管出口必須與大氣相通及沒有任何阻塞。
Water may drip from the Pressure and Temperature Relief Valve (PTV) drain pipe therefore the outlet of the pipe must be left opened to the atmosphere.
- 6.2 溫度及壓力排放閥的水管必須使用連續性向下的安裝方法，而水管周圍不能有結霜之情況發生。
The Pressure and Temperature Relief Valve (PTV) drain pipe must install continuously downward and the surroundings must not be frosted.
- 6.3 溫度及壓力排放閥必須作定期測試(建議每三個月)，以防阻塞情況發生。
The Pressure and Temperature Relief Valve (PTV) must be tested or operated regularly (suggested in every 3 months) to avoid blockage.
- 6.4 在加熱過程中，如溫度及壓力排放閥出現少量滴水屬正常情況，不須採取任何行動。
During heating process, small amount of water drips from the Pressure and Temperature Relief Valve (PTV) is a normal situation, NO action is required.
- 6.5 在加熱過程中，如溫度及壓力排放閥出現大量水和汽體排放時，則可能有以下問題：
If considerable amount of water flow through the PTV during the heating process, the possible reasons are as follows:
-溫度及壓力排放閥損壞
-PTV failure
-供水水壓過大
-Incoming water pressure is too high
-恆溫器損壞而導致水溫上升及壓力過強而排泄
-Thermostat failure
- 發生以上問題時，使用者立即應採取以下措施：
The following immediate action should be taken by the user:
-關掉電源
- Switch off the power
-關掉供水閘制
- Turn off the gate valve
-聯絡代理商或其認可的服務中心安排檢查或維修。
- Contact the Sole Agent or an authorized service centre for an inspection or maintenance work.

- 6.6 請勿在熱水器上放置任何物件。
Do not put any articles or objects on top of the water heater.
- 6.7 熱水器的供電電源需定期由合資格的技術人員進行檢查。如發現電線有任何損壞或過熱的情況發生，必須立即關閉電源，通知代理商或代理商授權的技術人員安排檢查。
Take regular check up of the power supply of the water heater by a qualified technician. If any damage or overheating of the cable is found, Must switch off the power supply immediately. Inform and arrange an inspection by the Agent or an authorized technician agreed by the Agent.
- 6.8 請勿與其他家電設備共用同一電源或不應使用電源延伸座接駁電源及熱水器。
Do not share the same power supply with other electrical appliances and do not use extension cable to connect the power supply and the water heater.
- 6.9 如熱水器發生故障，切勿自行維修或更換零件；請聯絡代理商或其認可的服務中心安排檢查或維修。
If there is a breakdown of the water heater, do not attempt to repair or replace any components parts by yourself; do contact the Agent or an authorized service centre for an inspection or maintenance work.
- 6.10 如將長時間不會使用熱水器，請關閉電源；在重新使用前，先進行檢查，開啟水龍頭並轉至紅點位置，確保水箱有足夠水量方可開啟電源。
The location for the installation of the water heater should have adequate floor drainage.
- 6.11 請使用原裝配件。禁止使用任何未經許可之配件。
Please use the original accessories and using any unauthorized parts or accessories is prohibited.
- 6.12 在停水期間，請勿開啟或使用本熱水器。
During water shortage, do not use or switch on the water heater.
- 6.13 安裝本熱水器之地台位置必須有適當的地台排水設施。
The location for the installation of the water heater should have adequate floor drainage.
- 6.14 如熱水器之水箱需作清潔或維修工作，請依照以下程序將水箱內之水完全排出後方可進行：
When the water storage heater require tank cleaning or repair, it is necessary to drain out all the water from the tank first. The procedures to drain off the tank are as follow:
- 6.14.1 先把來水閘制關上並把熱水器之電力斷路制關掉。
Close the gate valve and switch off the power supply of the storage water heater.
- 6.14.2 使用正確工具把底部的放水蓋鬆脫並打開，然後待水從內胆完全流出。
Use proper tool to open the bottom cover and loosen the drain stopper of the storage water heater; drain out all the water from the tank until empty.
- 6.14.3 在完成維修或清洗程序後，可以把放水蓋合上並收緊；把水閘掣和熱水龍頭打開直至水注滿內胆，方可重新開啟電源使用。
When repair or cleaning work is completed, tighten the drain stopper; open the gate valve and hot water tap until the tank is fully fill up with water, then power supply can be switch on for use.
- 6.15 本熱水器之最大入水壓力為1.0 MPa。
The maximum inlet water pressure of this water heater is in pascals: 1.0 MPa.
- 6.16 如供水系統的來水水壓超過0.5 MPa (5 Bar)，用戶必須額外加裝減壓器將水壓減低。
If the incoming pressure exceeds 0.5 MPa (5 Bar) a separate pressure control device should be installed.

恆溫控制	Thermal Control	由35°C到80°C可自由調校	35°C-80°C Adjustable
超溫斷路器	Thermal Cut-Out	90°C可重置式	90°C Manual -Resetable
測試/工作水壓	Test / Max. Working Pressure	2.0 MPa / 1.0 MPa	

JHR 系列產品規格		方型中央式 Multi-Point Shower Unit			
型號 Model	容量(公升) Capacity (Litres)	呎吋(毫米) Size(mm)			功率(千瓦) Power Rating (kW)
		高 H	闊 W	深 D	220 V
JHR-3.5(S)	15	430	308	308	3 / 4
JHR-6.5(S)	25	660	308	308	3 / 4
JHR-10 (S)	38	660	355	355	3 / 4
JHR-15 (S)	55	660	435	435	3 / 4
JHC 系列產品規格		圓型中央式 Multi-Point Shower Unit			
型號 Model	容量(公升) Capacity (Litres)	呎吋(毫米) Size(mm)		功率(千瓦) Power Rating (kW)	
		高 H	Ø直徑	220 V	
JHC-3.5(S)	15	430	306	3 / 4	
JHC-6.5(S)	25	660	306	3 / 4	
JHC-10 (S)	38	660	356	3 / 4	
JHC-15 (S)	55	660	432	3 / 4	
JHC-20 (S)	76	850	432	3 / 4	
JHC-25 (S)	95	1020	432	3 / 4	
JHC-30 (S)	115	960	504	3 / 4	
JHC-40 (S)	150	1200	504	3 / 4	

指示燈狀態 Light Indicator Status	狀況 Condition	一般原因 Reason in general
沒有顏色 No color	指示燈沒有亮起，沒有熱水供應 No Indicator and no hot water supply	未有連接電源 Power supply is cut off
沒有顏色 No color	指示燈長時間沒有亮起， 但有熱水供應 No Indicator for a long time but have hot water supply	指示燈損壞 Indicator lights is damaged
紅色 Red color	紅色加熱指示燈長時間亮起， 但沒有熱水供應 Heating indicator lights Red for a long time but no hot water supply	發熱管損壞 Heating element is damaged
紅色 Red color	紅色加熱指示燈長時間亮起，但出水溫度過熱 Heating indicator lights Red for a long time but water is too hot	恆溫掣故障或損壞 Thermostat failure or damage

- 9.1 電熱水器在自然損耗情況下，水箱保用十年，其他配件保用兩年。
Under the circumstances of natural wear and tear, the water tank will have a 10 year guarantee; other parts will have a 2 year guarantee.
- 9.2 上述之保養服務將會由購買日起開始生效，如產品在保養期內有任何問題發生，代理商將會提供維修或更換零件的服務。
The above warranty will start on the date of purchase. If any problem occurs within the warranty, the agent will be responsible for the maintenance or parts replacement that states within the warranty agreement.
- 9.3 如損壞由以下情況所引起，此保養將不會生效：
The warranty will become invalid if the damage is caused by the followings:
- 9.3.1 未有按照本說明書安裝或使用本熱水器；
Installation or usage that does not comply with the instruction manual;
- 9.3.2 使用非生產商提供之不合格配件；
Using any inappropriate accessories which are not provided by the manufacturer originally;
- 9.3.3 由未經許可之人員進行安裝或改裝本熱水器。
The water heater was installed for refitted by an unqualified person.
- 9.4 如熱水器用於商業用途，本保養將自動失效。
This warranty will no longer be valid if the water heater is used for commercial purposes.
- 9.5 如損壞是由自然災害、人為錯誤或疏忽、濫用或誤用所引致，本保養將自動失效。
This warranty will not cover damages that caused by natural disasters, human errors, misused or any other inappropriate manners.
- 9.6 任何公共交通工具不能到達之偏遠地區或非辦公時間內提供服務，本公司將會收取附加費。
A supplementary charge will apply where the service location cannot be accessed by public transports and or when service is required during non office hours.
- 9.7 2年保用期屆滿後，本公司會另外再保用熱水器內膽8年。此保用只適用於熱水器內膽之維修，所有檢查、運送及裝拆費用均須額外收費。
When the 2 years warranty period is over, A-Plus will provide an additional 8 years of warranty on the inner tank. This additional warranty applies only to the maintenance of the inner tank. Additional cost will apply on inspection, transportation and labour.
詳情請向本公司客戶服務部查詢。
For more enquiries please contact our Customer Service hotline.
- 9.8 此服務只適合於香港使用
This service is only valid in Hong Kong.

總代理 Sole Agent



A-PLUS (HK) GROUP LTD.
愛家(香港)集團有限公司

香港葵涌青山公路403號匯城集團大廈5樓A-E室

Unit A-E, 5/F, Reason Group Tower, 403 Castle Peak Rd., Kwai Chung, N.T., HongKong

電話號碼 Tel. : 3563 7238 傳真號碼 Fax. : 3563 8793

電郵 E-mail : company@aplusgroup.hk

網址 Website : www.aplusgroup.hk

APJHWA1707MAN

_076M